

To be a Digital-Professional!

Digital driving and switching of dual-coil drives with DiCoStation, DigitalBooster DB-4 and 2-rails conductor

The main focus of this chapter shall cover the simple installation and use of the first Turnout Decoders "S-DEC-4-DC" for dual-coil drives for switching turnouts or semaphore signals.

The first step by the construction of a digital controlled model railway layout is the installation of the digital driving. For the realization of the digital driving has the DiCoStation to be connected to the power supply and to the rails via a digital amplifier (=DigitalBooster "DB-4").

The second step is the installation of the digital switching. The first decoders can now be connected to the supply voltage and to the digital voltage.

Many of the described cable colors are typical colors used within the installation of a digital model railway. It is within your option to use cable colors to your requirement. Nevertheless you should assure right at the beginning: remain to the selected cable color system and make a careful documentation for possible future fault diagnosis, for extending the system or for modification of the system.

■ Booster = Amplifier

■ General Note

Supply voltage to the DiCoStation

If the DiCoStation will be combined with the DigitalBooster „DB-4“, it has to get the power supply via the 2-poles clamp KL1.

The voltage can be supplied by a switch mode power supply (direct current / DC / =) or by a model railway former (alternating current / AC / ~). For the direct current supply will be a switch mode power supply with a voltage of 15 to 24 volt suitable. The positive pole of the direct current has to be connected to the input yellow and the negative pole to the input brown of the clamp KL1.

If the power supply comes from a model railway transformer with 14 to 18 volt does the polarity of the alternated current on the clamp KL1 no matter. If the poles at the transformer are marked with yellow and brown the connection has to correspond to the marking of the clamp KL1 of the DiCoStation.

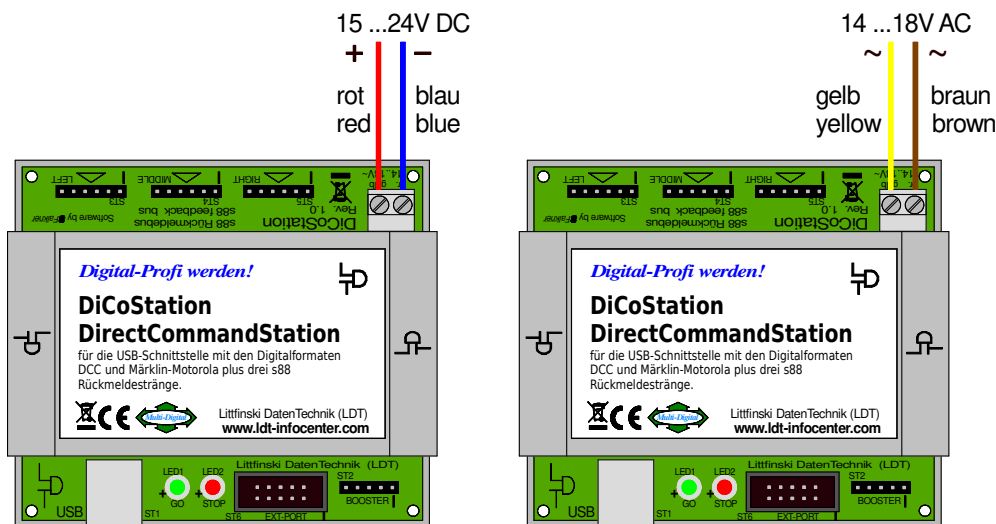

■ Power supply to the DiCoStation (page_1696)

Connecting the DiCoStation with the DigitalBooster DB-4

The DiCoStation will be connected to the first DigitalBooster “DB4” via the Boosterbus cable “Kabel Booster 1m”.

The one side of the bus-cable will be connected to the 5-poles pin-bar IN of the booster and the other side to the 5 poles pin-bar ST2 of the DiCoStation which is marked with BOOSTER.

Insert the plug of the bus cable in that position onto the 5-poles pin bar of the “DB-4” and the DiCoStation that the white single wire will correspond to the position of the white marking on printed circuit board. Take care that the plugs are not offset by one or more pins.

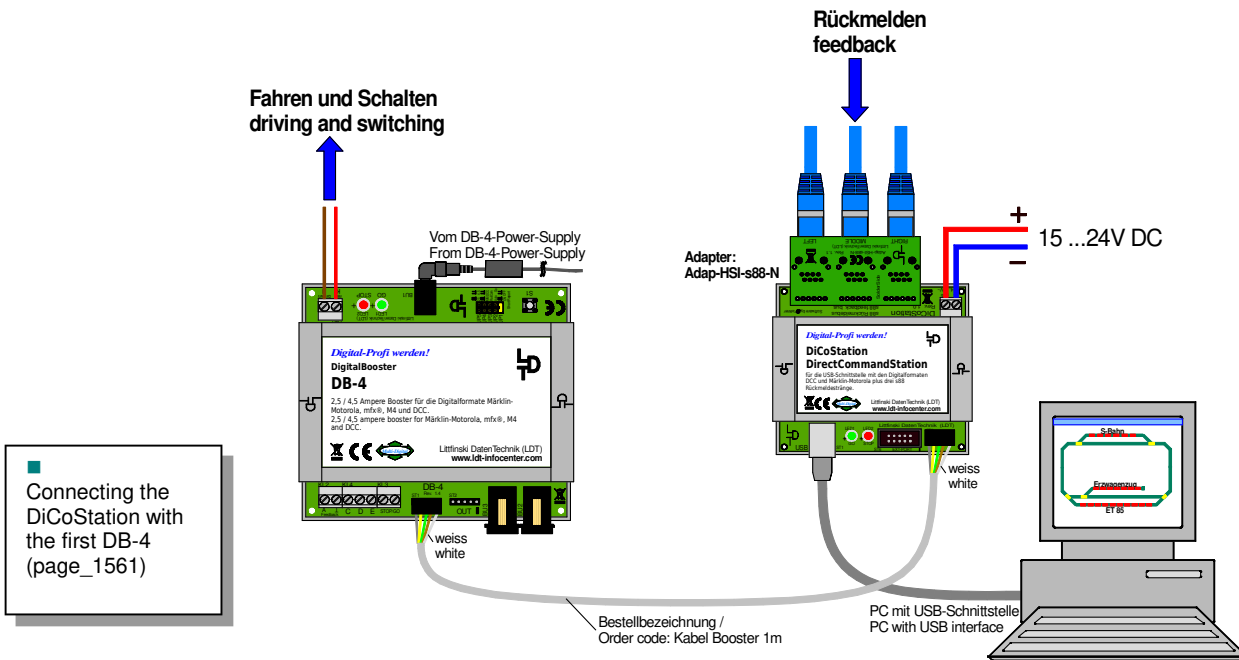

The second DigitalBooster “DB-4” will be connected to the first with a further booster bus cable “Kabel Booster 1m”. Each booster supplies current to an own rail section. The rail sections are electrically isolated against each other by splitting points.

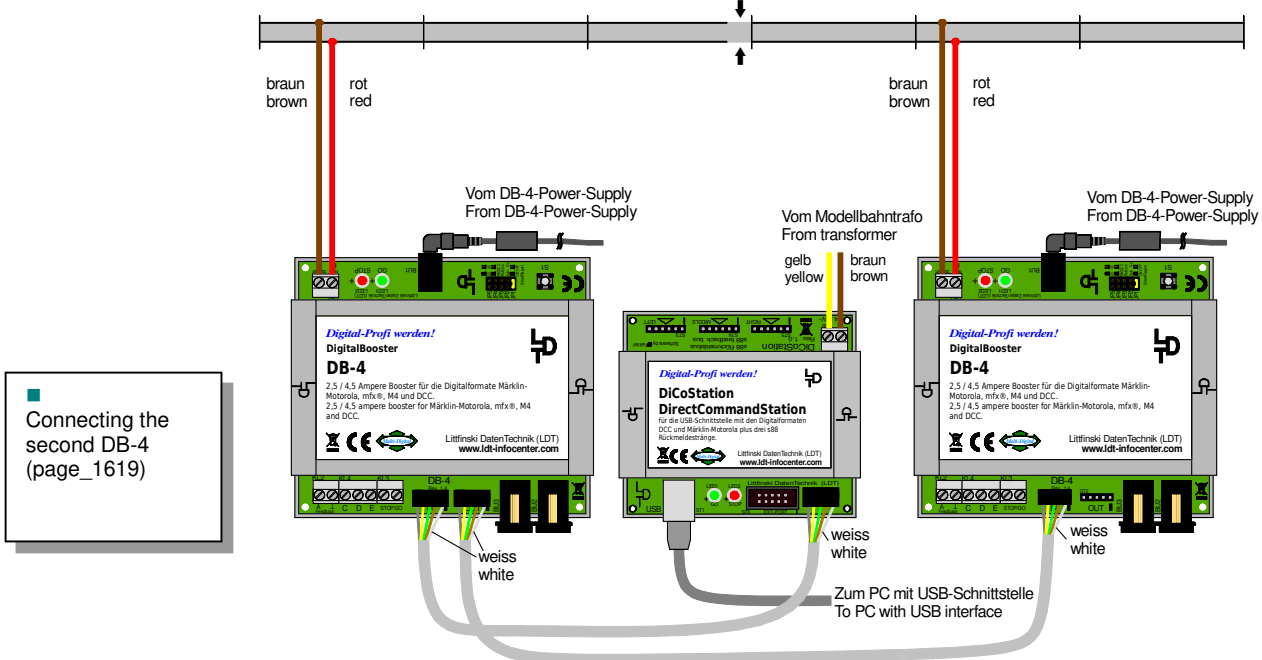

For the supply of the Booster “DB-4” is the 120VA switched mode power supply “DB-4-PowerSupply” suitable. At the “DB-4-PowerSupply” shall be the power supply of 15 to 24V adjusted. This will be the value of the digital voltage from the “DB-4”.

The Booster “DB-4” is able to supply a digital current of up to max. 4.5 Ampere to the different digital components (locomotives with decoders, turnout- and switch-decoders etc.).

For the wires of the supply cables (yellow / brown) and as well for the rail connections (red / brown =digital current) the following wire sizes are recommended:

length of the cable	recommended cross section
up to 3 m	0.75 mm ²
up to 6 m	1.5 mm ²
up to 10 m	2.5 mm ²
more as 10 m	4.0 mm ²

For preventing power losses is it recommended to use a (first) mains ring conductor with connections to the rail system (red / brown) at distances of 1.5 to 2m.

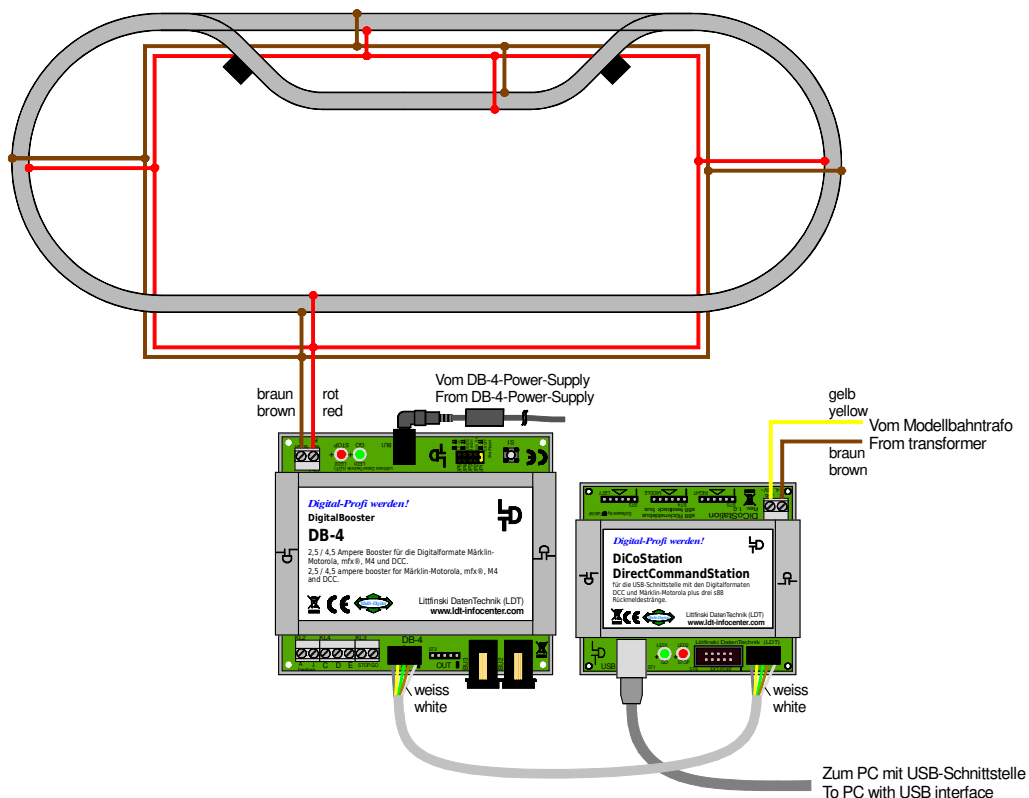

■ Rail ring conductor with supply connections (page_1620)

Each plugged rail connection will contain an electrical resistance. This resistance will be enlarged by corroded contacts etc.

The resulting voltage drop at the rail connections reduces the digital voltage and it can be possible that “remote” track sections will eventually not get the full digital voltage – disturbances or inexplicable abnormal behavior can be expected. A sufficient diameter of the supply-wire contains a considerable lower resistance and assures therefore the full supply of the voltage to the rails.

THE FIRST TURNOUT-DECODERS (*S-DEC-4-DC*)

Now to the second step for the digital switching at your digital model railway layout. Also the Turnout-Decoders requires a connection to the power supply (12 – 18 V ~) and to the digital voltage. All digital commands as well as to the loc-decoders will be transmitted on this way.

■ General Note

For a 2-conductor direct current layout with a typical DCC-data format is it recommended to select the DCC-data format for the turnout decoders as well. It would be possible to control the system with the DiCoStation via the MOTOROLA-format (using the turnout decoder “*S-DEC-4-MM*”).

But this would result into an extended reaction time of the digital system because mixed data formats would be transmitted. Therefore prevent using various digital protocols and use the DCC-data format for the 2-conductor direct current supply and the Turnout Decoder “*S-DEC-4-DC*” only.

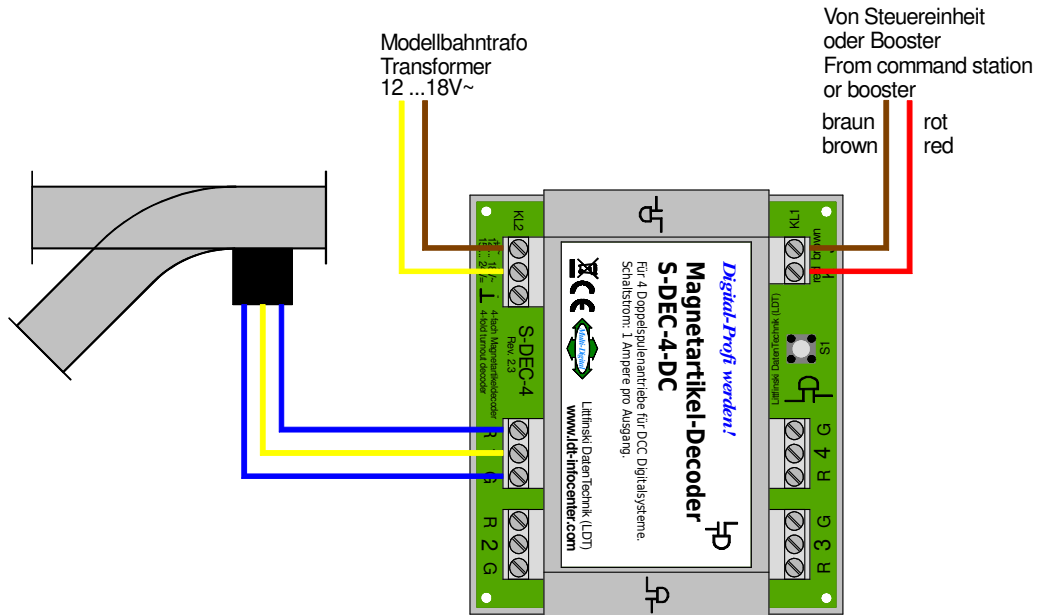

■ Connection of the Turnout-Decoder *S-DEC-4-DC* (page_329)

Power supply (**yellow / brown** cables at the above sample) will be required for the module itself and the switching of the coil drives. The decoder module requires a spacing current flow of about 0.1 Ampere. Each output can cover a maximum switching current load of up to 1 Ampere.

 By connecting the supply voltage of 12 – 18 Volt ~ please pay careful attention that you use the two inputs of the clamp KL2 which are marked with “~”. One of the two terminals of the supply voltage should never be connected to the ground output “⊥” of the 3 poles clamp KL2. In this case the decoder will be destroyed as shown within the following connection sample.

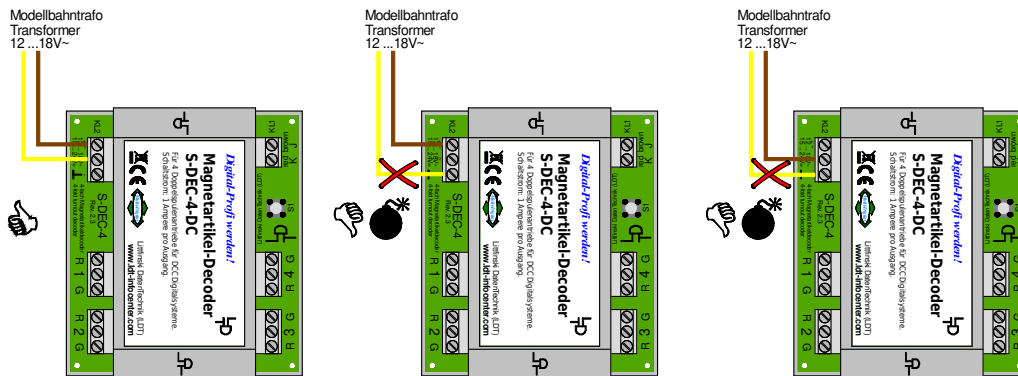

■ Correct connection of the external supply voltage (page_506)

The turnouts or signals have to be connected with three cables (**blue / yellow / blue**), which can be of a preferable short length, by a considerable close distance of the decoder to the respective turnout or signal. The common conductor of the turnout- or signal-drive (**yellow**) shall be connected to the middle contact of the decoder module marked by a digit. The clamps marked with “G” and “R” are supposed for the coil drives and are indicating the turnout position to be switched (G for straight and R for round).

If it is required to extend the connection cables of a turnout drive it has to be taken care of a sufficient diameter of the connection wires. For a maximum current of 1 Ampere at the decoder output is the ordinary used wiring of 0.14 mm² not sufficient. We recommend to use wires of 0.5 mm² for a sufficient installation.

■ General Note

If the available digital current supply (each DigitalBooster “DB-4” supplies a digital current of maximal 4.5 Ampere) for driving and operating the layout will be insufficient is it required to use an additional digital amplifier. This requires naturally additional wiring installation and further cost (expensive digital current).

The next sample shows the connection of two of four possible turnouts and the connection of a further decoder module for additional four turnouts.

It is recommended to install a separate second main ring conductor for the digital current to the turnout- and switch decoders (**red / brown**) and a third main ring conductor for the voltage supply (**yellow / brown**).

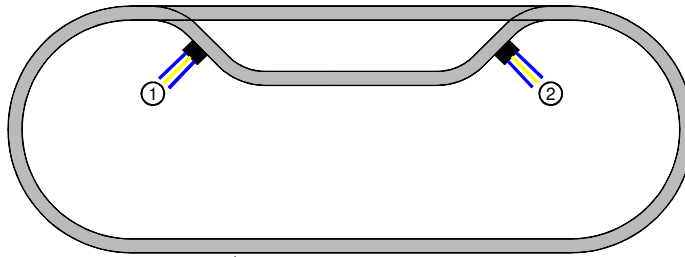

Connecting several Turnout Decoders S-DEC-4-DC (page_1621)

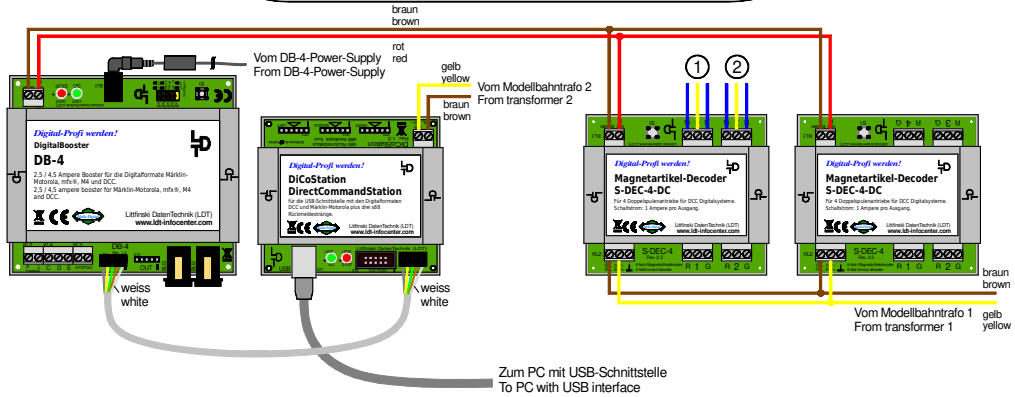

The digital information for the accessory decoders should never be taken directly from the rails. The driving locomotives can influence the digital signal by producing continually a kind of loose contact signal. This can result to the problem that the decoder cannot understand the signal. For this reason will be the loc commands continually repeated.

Especially for the switch commands which will not be transmitted several times as done by the loc commands is it possible that commands will be getting lost if the digital information have been taken directly from the rails.

Ringleitung Digitalstrom
 Ring conductor digital current

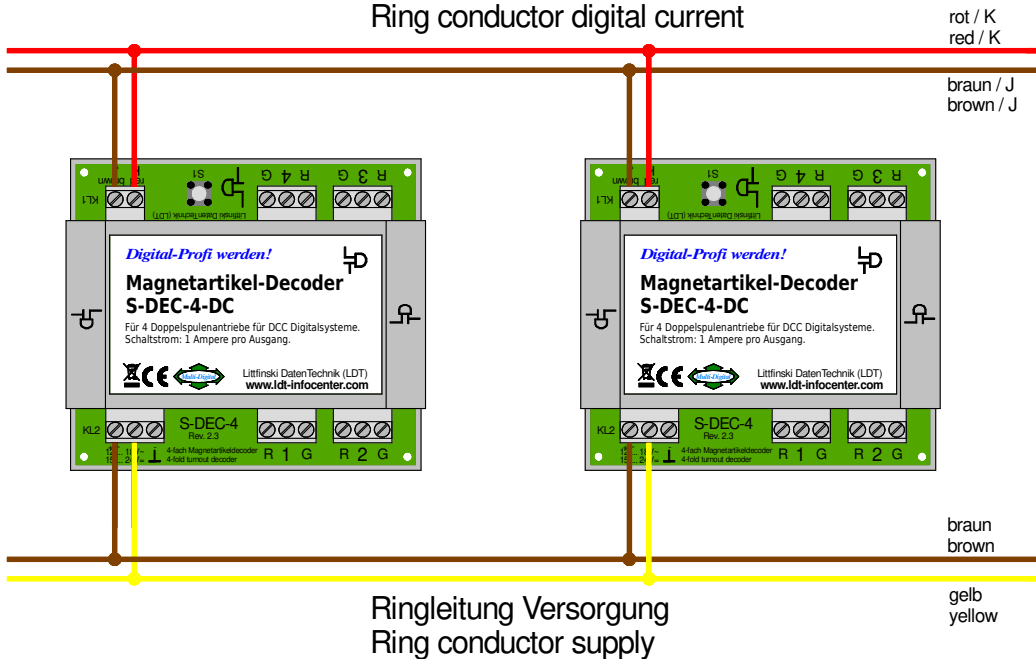

2. and 3. Main Ring Conductor for accessory decoders (page_003)

There are as well some recommendations for the wire cross-section dimension of the two main ring conductor wires. As there will be a low current flow only the wire dimension can be a little smaller.

length of the cable	recommended cross section
up to 10 m	0.75 mm ²
more as 10 m	1.0 – 1.5 mm ²

At least after completion of the wiring installation you should start the first test and the placing of suitable a digital address for the turnout (or signal).

THE FIRST PROGRAMMING

The assignment of digital addresses has to be carried out individually for each module. The address is valid for the respective complete group of four (e.g. 1 - 4, 5 - 8, 9 - 12 etc.). For setting the address (= read-in address) you have to connect a turnout to the output 1 at the module.

The turnout will start switching at a 1.5 second interval after activating the programming key at the decoder. The decoder module is now in a learning mode. Now is it required to select and activate a turnout (1 – 4, 5 – 8, etc.) at the central unit. The decoder module takes over the four addresses for the four outputs and confirms the setting by switching the connected turnout for a short period a little faster. Depressing again the programming key at the decoder will complete the setting of addresses. The addresses are now permanently stored at the decoder.

Our tip: Carry out the set-up of digital addresses before installing the decoder module below the layout because the handling of the module with all connections is much easier at a working bench. After address setting please mark the module with the assigned digital addresses (e.g. label marked with a pencil “5 – 8” for the second group of four addresses).

■ General Note

With this procedure the functional test has been already performed and a later malfunction after installation (e.g. defect module) can be prevented. After final installation of the unit this would be a difficult time consuming procedure.

SUPPRESSION OF INTERFERENCES

End-off switched coil drives of turnouts can initiate interferences and therefore influencing the digital system e.g. with unreliable switching of turnouts. This problem can be solved by slipping 10 ferrite pearls onto the common connection wire (**yellow**) of the turnout drives. This has to be done very close to the coil housing.

■ Technical Tip

The resistor is available as accessory by LDT under the order code “RES4R7”. There will be no change within the connections or the operation of the turnouts as well as on the programming of the decoder. For the suppression of interferences by those end-off switched turnouts is it recommended to apply the ferrite pearls as well on the common connection (**yellow**) of the turnouts ⇒ “Suppression of interferences” (Page 8).

FURTHER INFORMATION

Additional information about the operation of digital model railway components and further helpful connection samples are available within the operation instructions received with every purchased module and device and at our extensive Internet page. All mentioned sample connections can be loaded down as PDF files (e.g. page_1696.pdf) and printed at an A4 format.

Internet: www.ldt-infocenter.com

Authors: Harry Kellner and Peter Littfinski

Subject to technical changes and errors.
© 03/2022 by LDT