

Gleisbelegtmeldung in der Kehrschleife mit KSM-SG / s88-Standardkabel Occupancy detection at a reversing loop with KSM-SG / s88 standard cable

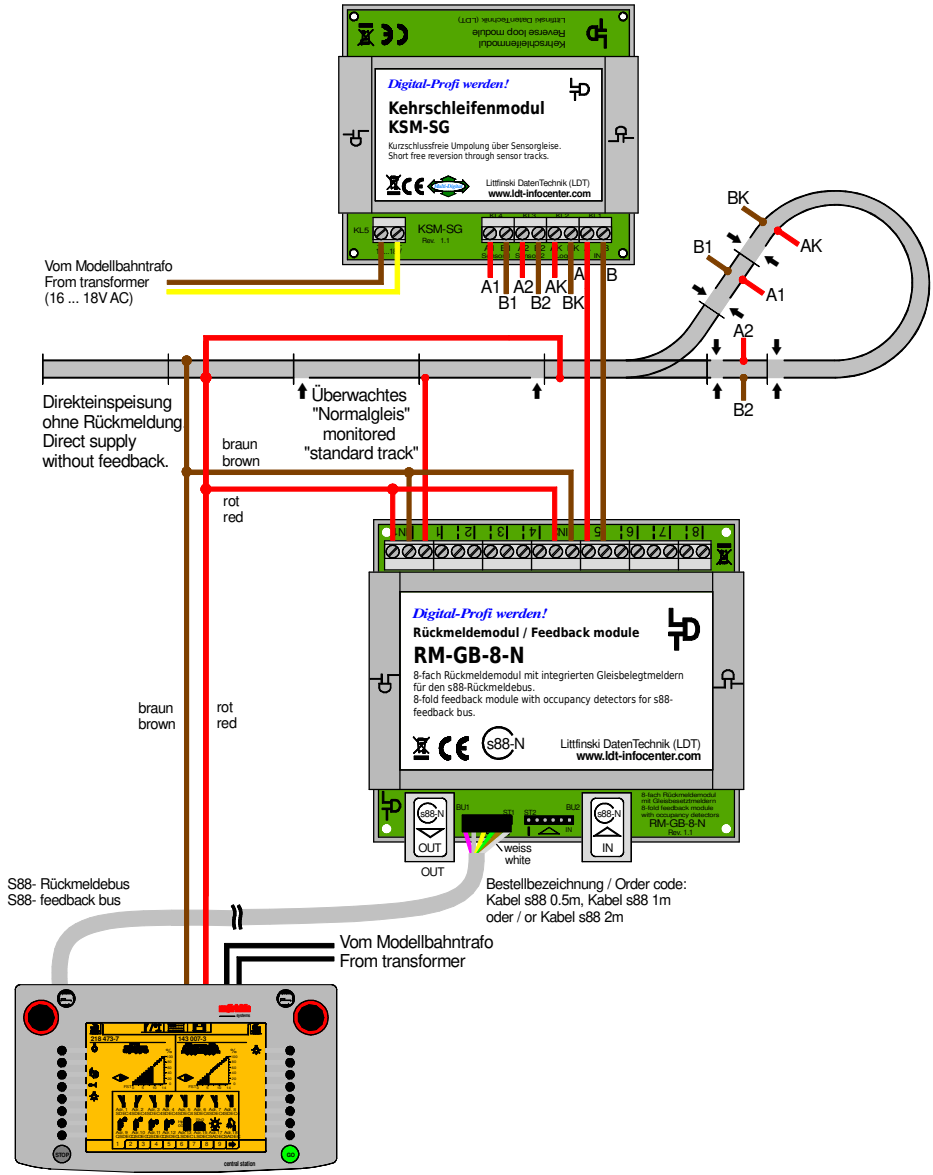

Technische Änderungen und Irrtum vorbehalten.
 Subject to technical changes and errors.
 © 04/2020 by LDT