



4-fold decoder for motor driven turnouts

with external power supply possibility

from the *Digital-Professional-Series* !

M-DEC-DC-F Part-No.: **410412**

>> finished module <<

Suitable for the DCC-Format:

e.g. Lenz-, Arnold-, Roco-, LGB-Digital, Intellibox, TWIN-CENTER, Digitrax, Zimo, Märklin-Digital=, EasyControl, KeyCom-DC, ECoS, DiCoStation and others

Turnouts can be switched as well via loc-addresses (e.g. Lokmaus 2® and R3®)

For the digital control of :

⇒ Up to four turnout motor drives.
(e.g. drives from Fulgurex, Pilz or Hoffmann/Conrad)

⇒ Motor current per output up to 1A.

This product is not a toy! Not suitable for children under 14 years of age!
The kit contains small parts, which should be kept away from children under 3!
Improper use will imply danger of injuring due to sharp edges and tips!
Please store this instruction carefully.



blue point



Introduction/Safety instruction:

You have purchased the 4-fold decoder **M-DEC-DC** for motor driven turnouts for your model railway as a kit or as finished module supplied within the assortment of Littfinski DatenTechnik (LDT).

We are wishing you having a good time using this product.

The **M-DEC-DC** (receiver device is marked with a blue dot) is suitable for the **DCC Data format**, used for instance within the systems of **Arnold-Digital, Intellibox, Lenz-Digital Plus, Roco-Digital, TWIN-CENTER, Digitrax, LGB-Digital, Zimo, Märklin-Digital=, EasyControl, KeyCom-DC, ECoS and DiCoStation**. The decoder **M-DEC-DC** can not only switch turnouts via the **turnout addresses** but also responds to **loc-addresses**. Therefore is it possible to shift turnouts with the functional keys **F1 to F4** of the **Lokmaus 2®** or **R3®**.

The finished module comes with **24 month warranty**.

- Please read the following instructions carefully. Warranty will expire due to damages caused by disregarding the operating instructions. LDT will also be not liable for any consequential damages caused by improper use or installation.
- Also, note that electronic semiconductors are very sensitive to electrostatic discharges and can be destroyed by them. Therefore, discharge yourself before touching the modules on a grounded metal surface (e.g. heater, water pipe or protective earth connection) or work on a grounded electrostatic protection mat or with a wrist strap for electrostatic protection.
- We designed our devices for indoor use only.

Connecting the decoder to your digital model railway layout:

- **Attention:** Before starting any installation switch off all power supply to the digital layout by pushing the stop button or disconnect all main supply to the transformers.

The decoder receives the **digital information** via the clamp **KL2**. Connect the clamp directly to the command station or to a booster assuring the supply of digital information free from any interference.

The DCC-Digital-Systems uses different color codes respectively indications for the two digital cables. Those markings are indicated next to the clamp **KL2**. These markings have not necessarily to be maintained correct as the decoder converts the signal automatically to be correct.

The decoder receives the **voltage-supply** via the two-pole clamp **KL1**. The voltage shall be in the range of 12 to 18V~ (alternating voltage output of a model railway transformer) or 15 to 24Volt = (direct voltage output of an insulated power supply unit).

Programming the decoder address:

To program the decoder-address a motor driven turnout has to be connected to the output 1 (clamp **KL9**) of the decoder.

- Switch on the power supply of your model railway.
- Adjust the **speed** of all connected speed controller to **zero**.
- Press the **programming key S1**.
- The turnout drive connected to output 1 will now move a little every **1.5 seconds**. This indicates that the decoder is in the **programming mode**.
- Is the motor not moving is it possible that the motor drive contains directional diodes. In this case switch off the power supply and turn around the two connection wires on output 1. After switching power on the turnout drive should move at a 1.5 second interval.
- Switch now one turnout of a **group of four** assigned to the decoder via the keyboard of the control unit or via a remote control unit.
- For programming the decoder address you can also release a turnout switch signal via a personal computer.

Remarks: The decoder-addresses for magnet accessories are combined in **groups of four**. The address 1 to 4 build the first group. The address 5 to 8 build the second group etc.

Each **M-DEC-DC** decoder can be assigned to any of these groups. Which turnout of a group will be activated for the addressing does not matter.

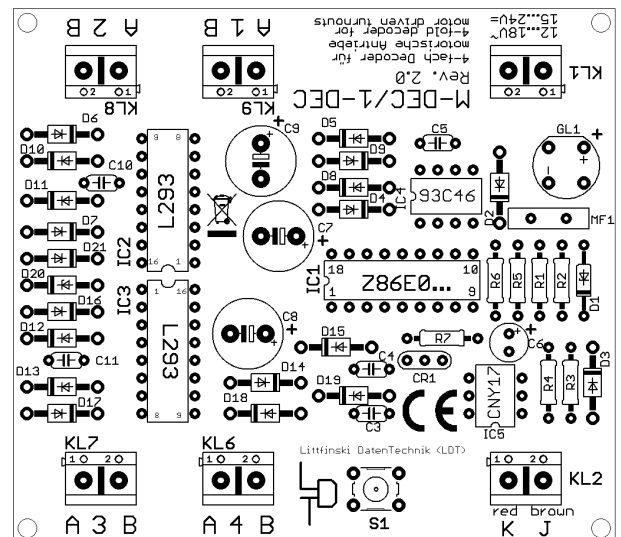

- If the decoder has recognized the assignment correctly the connected turnout will move a little faster. Afterwards the movement slows down to the initial 1.5 seconds again.
- Leave the programming mode by pressing the programming key S1 again. The decoder address is now permanently stored but it can be changed at any time by repeating the programming as described above.
- If you press the first key of the programmed group of keys or you send a switch signal for this turnout from a PC the addressed turnout drive should move into the called direction until end-stop.

Switching turnouts via loc-addresses (e.g. Lokmaus 2® or R3®):

The decoder **M-DEC-DC** makes it possible to switch motor driven turnouts via **loc-addresses**. For example switching with the **functional keys F1 to F4** of the **Lokmaus 2® or R3®**.

The **function key F1** will shift the **drive at the output 1** and the **key F2** will shift the **turnout at the output 2** etc.

Each **stroke on a function key** will **shift the respective turnout** from round to straight or vice versa.

Also for programming the loc-addresses a turnout motor-drive has to be connected to the output 1 of the decoder.

- Switch the **power supply** of your model railway on.
- Adjust the **speed** of all connected speed controller respectively Lokmauses to **zero** (center position of the adjusting dial).
- Press the **programming key S1**.
- The motor drive connected to output 1 shall move now **automatically every 1.5 seconds**. This indicates that the decoder is in the **programming mode**.
- Adjust now on one of the Lokmauses the required address and **turn the speed adjusting dial** off from the center position. If the decoder has recognized the assignment correctly the connected **turnout drive will move** now a little **faster**. The decoder **M-DEC-DC** will accept **loc-addresses between 1 and 99**.
- Adjust the **speed now to zero** again. The turnout will move now a little slower.
- Press the **programming key S1** again for **leaving the programming mode**.
- If you press **functional key F1** you can shift the **turnout of the output 1** with **each stroke**. If there are turnouts connected on output 2 to 4 of the decoder **M-DEC-DC** you can shift the respective registered turnouts with the programmed loc-addresses with each stroke of the function keys F2 to F4.

Please attend to the following:

- All 4 **decoder outputs** can supply a motor current of **1 Ampere**. As the moving time of the drives is only some seconds the **tracking time** of the decoder output is adjusted to **10 seconds**. This indicates that the respective output will be **switched voltage free** 10 seconds after the end of the switch command. This assures that a **defect end-switch will not destroy a drive** with continuous current.
- The motors of turnout drives can create considerable **electromagnetic interference**. Normally the decoder **M-DEC** will not be influenced by this interference. But in case the decoder will be influenced please check the **turnout drive installation cables**. Those cables should not wrap or cross the decoder closely. Install the cables that way that they go straight away from the clamps of the decoder. If limited space requires a bad installation layout and the function of the decoder will be disturbed please push about 5 ferrous pearls onto each motor cable.
These ferrous pearls are available at electronic shops or at LDT with the order code `FP`.
Another possibility is to solder an **interference capacitor** (between 1nF and 10nF) across each motor. **Fulgurex** drives need this capacitor **in any case**.

Accessory

For the assembly of the **M-DEC** below your layout base plate is our assembly set **MON-Set** recommended. For the ready assembled kits and the finished modules from version 2.0 we offer a suitable case under the order code **LDT-01**.

Sample Connections:

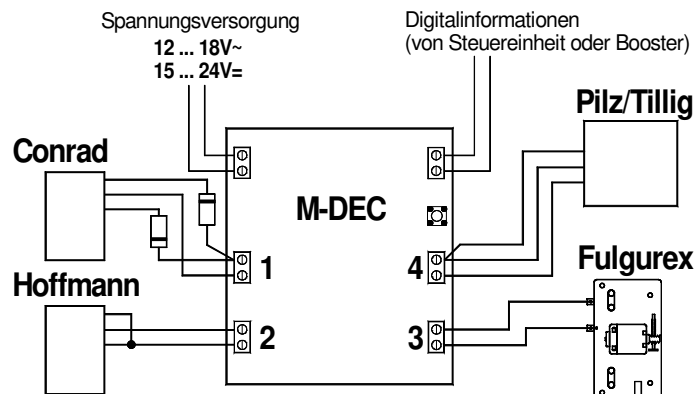

The above draft provides an example how to connect the different drives directly to the **M-DEC-DC** without any additional circuitry.

Further application examples can be found in the **Internet** on our **Web-Site** (www.ldt-infocenter.com) at the section **downloads/sample connections**.

Trouble shooting:

What to do if something is not working as described above?

If you have purchased the decoder as a kit please check carefully all parts and soldered joints.

Here some possible functional errors and possible solutions:

1. During **programming of the decoder addresses** the motor moves within 1.5 seconds, but does not **confirm** the programming with **faster movement** by **pressing any key**.
 - **Interfered digital information at KL2** respectively considerable **lost of voltage** at the **tracks** or at the **installation!** Connect the decoder directly with cables to the digital control unit or to the booster instead to the tracks.
2. The turnout connected to output 1 will move always at a **faster sequence** after activating the programming key S1.
 - Start **programming** the decoder for motor driven turnouts **M-DEC-DC immediately after switching-on** the digital central unit before any loc is traveling on the track.
 - Perform a **RESET** of the digital central unit. All stored data will be preserved but the **address-repeating-memory** will be **deleted**. For **Intellibox** and **TWIN-CENTER** please switch-on the unit and press the keys **GO** and **STOP** simultaneous until the report "reset" can be read at the display.
3. The drive moves **not until the end switch** but **stops** after a **short movement**. The decoder does not show any reaction after some commands.
 - This can happen especially by **Fulgurex**-drives **without interference capacitor**. Solving: solder an interference capacitor (**1nF**) directly to the motor connection clamps.

Made in Europe by
Littfinski DatenTechnik (LDT)
Bühler electronic GmbH
Ulmenstraße 43
15370 Fredersdorf / Germany
Phone: +49 (0) 33439 / 867-0
Internet: www.ldt-infocenter.com

Subject to technical changes and errors. © 09/2022 by LDT
Arnold, Märklin, Lenz, Digitrax, Roco and Zimo are registered trade marks.