



4-fold decoder for motor driven turnouts

with external power supply possibility

from the *Digital-Professional-Series* !

M-DEC-MM-G Part-No.: 410513

>> finished module in a case <<

Suitable for the Märklin-Motorola-Format:

(e.g. Märklin-Digital~ [Control Unit, Central Station 1 and 2], Intellibox, EasyControl, ECoS, KeyCom-MM, DiCoStation EDiTS, EDiTS pro and others)

For the digital control of :

⇒ Up to four turnout motor drives.
(e.g. drives from Fulgurex, Pilz or Hoffmann/Conrad)

⇒ Motor current per output up to 1A.

This product is not a toy! Not suitable for children under 14 years of age!
The kit contains small parts, which should be kept away from children under 3!
Improper use will imply danger of injuring due to sharp edges and tips! Please store this instruction carefully.



Introduction/Safety instruction:

You have purchased the 4-fold decoder **M-DEC-MM** for motor driven turnouts for your model railway as a finished module in a case. The **M-DEC-MM** is a high quality product that is supplied from the *Digital-Professional-Series* of Littfinski DatenTechnik (LDT).

We wish you having a good time using this product.

The decoder **M-DEC** of the *Digital-Professional-Series* can be easily installed and used on your digital railway.

The **colored dot** on the receiver device indicates to which digital system the decoder can be adapted.

In case the receiver device is marked **blue** the **M-DEC** will be suitable for the **DCC Data format**, used for instance at the systems of **Arnold-Digital, Intellibox, Lenz-Digital Plus, Roco-Digital, TWIN-CENTER, Digitrax, LGB-Digital, Zimo, Märklin-Digital=, EasyControl, KeyCom-DC, ECoS** and **DiCoStation**.

In case the receiver device is marked **red** the decoder is suitable for **Märklin-Digital~** respectively for **Märklin-Motorola** layouts.

The finished module in a case comes with **24 month warranty**.

- Please read the following instructions carefully. Warranty will expire due to damages caused by disregarding the operating instructions. LDT will also be not liable for any consequential damages caused by improper use or installation.
- We designed our devices for indoor use only.

Connecting the decoder to your digital model railway layout:

- **Attention:** Before starting any installation work switch off the supply voltage to the digital installation by disconnect all transformer power plugs of the main supply.

The decoder receives the **digital information** via the clamp **KL2**. Connect the clamp with a rail or even better connect the clamp **directly** to the **command station** or to a **booster** assuring supply of digital information **free from any interference**.

Pay attention to the mark at clamp **KL2**. The color markings '**Black/Schwarz**' and '**Red/Rot**' next to the clamp are used for **Arnold-Digital (old)** and **Märklin-Digital=**.

Other systems uses the letters '**J**' and '**K**'.

If you use the decoder with **Märklin Digital~ components** or with **Intellibox** you have to connect the digital wires to '**red/rot**' and '**brown/braun**'.

The decoder receives the **voltage-supply** via the two-pole clamp **KL1**. The voltage shall be in the range of 12 to 18V~ (alternating voltage output of a model railway transformer) or 15 to 24V= (direct voltage output of an insulated power supply unit).

Programming the decoder address:

To program the decoder address a motor driven turnout has to be connected to the output 1 (clamp **KL9**) of the decoder.

- Switch on the power supply of your model railway.
- Depress the **programming key S1**. Do not touch the integrated circuits of the pc-board because any electrostatic discharge can destroy the IC's.
- The turnout drive connected to output 1 will now move a little every **1.5 seconds**. This indicates that the decoder is in the **programming mode**.

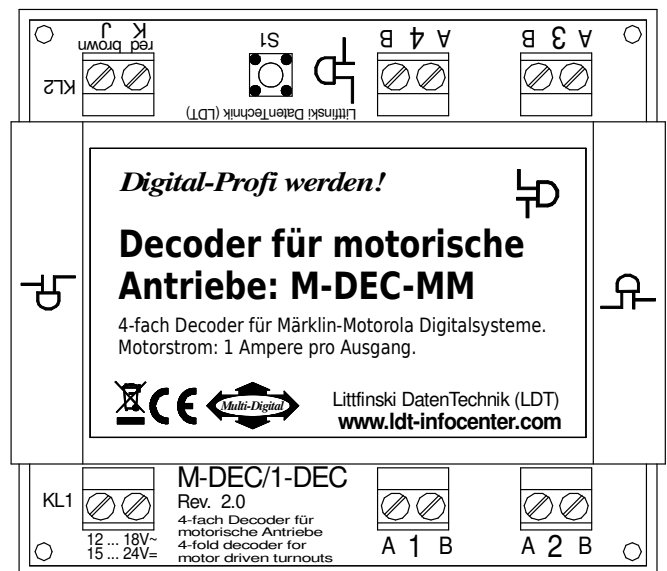

Is the motor not moving it is possible that the motor drive contains directional diodes. In this case switch off the power supply and turn around the two connection wires on output 1. After switching power on the turnout drive should move of a 1.5 second interval.

- Depress now one key of the key group to be assigned to the decoder. For programming the decoder address you can also release a turnout switch signal via a personal computer.

Remarks: The decoder addresses for magnet accessories are combined in **groups of four**. The address 1 to 4 build the first group. The address 5 to 8 build the second group etc. Each **M-DEC** decoder can be assigned to any of these groups. Which turnout of a group will be activated for the addressing does not matter.

- If the decoder has recognized the assignment correctly the connected turnout will move a little faster. Afterwards the movement slows down to the initial 1.5 seconds again. In case the decoder will not recognize the address it could be that the two digital information connections (clamp 2) are wrong connected. For testing this, switch the power supply off, exchange the connection on KL2 and start addressing again.
- Leave the programming mode by depressing the programming key S1 again. The decoder address is now permanently stored but it can be changed at any time by repeating the programming as described above.
- If you depress the first key of the programmed group of keys or you send a switch signal for this turnout from a PC the addressed turnout drive should move into the called direction until end stop.

Please attend to the following:

- All 4 **decoder outputs** can supply a motor current of **1 Ampere**. As the moving time of the drives is only some seconds the **tracking time** of the decoder output is adjusted to **10 seconds**. This indicates that the respective output will be **switched off from power** 10 second after the end of the switch command. This assures that a **defect end switch** will **not destroy a drive** with continuous current.
- The motors of turnout drives can create considerable **electromagnetic interference**. Normally the decoder **M-DEC** will not be influenced by this interference. In case the decoder will be influenced please check the **turnout motor installation cables**. Those cables should not wrap or cross the decoder closely. Install the cables that way that they go straight away from the clamps of the decoder. If limited space requires a bad installation layout and the function of the decoder will be disturbed please push about 5 ferrous pearls onto each motor cable.

These ferrous pearls are available at electronic shops or at LDT with the order code `FP`.

Another possibility is to solder **an interference capacitor** (between 1nF and 10nF) across each motor. **Fulgurex** drives need this capacitor **in any case**.

Sample connections:

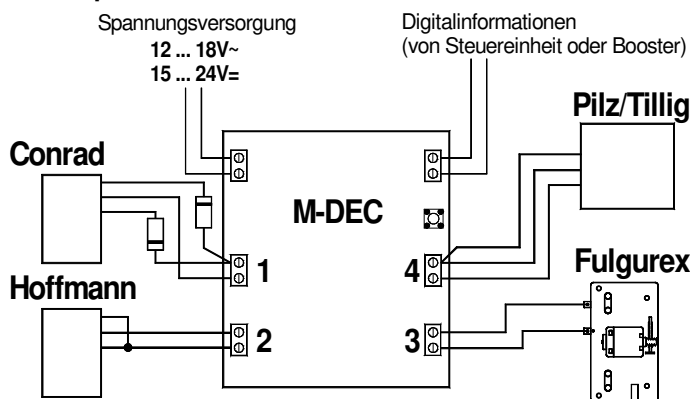

The above draft provides an example how to connect the different drives directly to the **M-DEC** without any additional circuitry.

Further application and circuit examples can be found in the **Internet** on our **Web-Site** (www.ldt-infocenter.com) at the section **downloads/sample connections**.

Trouble shooting:

What to do if something is not working as described above? If you have purchased the decoder as a kit please check carefully all parts and soldered joints.

Here some possible functional errors and possible solutions:

1. During **programming of the decoder addresses** the motor moves within 1.5 seconds, but does not **confirm** the programming with **faster movement** by **pressing any key**.
 - **Change cable connections at KL2.**
 - **Interfered digital information at KL2** respectively **lost of voltage** at the **tracks** or at the **installation!**
Connect the decoder directly with cables to the digital control unit or to the booster instead to the tracks. Increase the cable diameter for long distances.
2. The **programming of the decoder address** functions as described, nevertheless the connected **turnouts** will not be activated.
 - **Interfered digital information** on **KL2** respectively larger **lost of voltage** at the **tracks** or the **installation** result to unsafe data transfer! Connect the decoder directly to the command station or the booster. Increase the cable diameter of long distance connection cables.
3. The drive moves **not until the end switch** but **stops** after a **short movement**. The decoder shows not any reaction after some commands.
 - This can happen especially by **Fulgurex**-drives **without interference capacitor**. Solving: solder an **interference capacitor (1nF)** directly to the motor connection clamps.

Further Products from our *Digital-Professional-Series*:

S-DEC-4

4-fold turnout decoder for four magnet accessories with free programmable decoder addresses and possible separate power supply.

SA-DEC-4

4-fold switch decoder with 4 bistable relays for switching up to 2A each. With free programmable decoder addresses.

LS-DEC

Light signal-Decoder for up to **four LED-equipped signals**. **Signal aspects** will be **switched as real by up- and down dimming** and will be switched directly via decoder addresses.

All components can be purchased as easy to **assemble complete kits**, as **finished modules** or as ready **finished modules in a case**.

Made in Europe by
Littfinski DatenTechnik (LDT)
 Bühler electronic GmbH
 Ulmenstraße 43
 15370 Fredersdorf / Germany
 Phone: +49 (0) 33439 / 867-0
 Internet: www.ldt-infocenter.com

Subject to technical changes and errors. © 09/2022 by LDT
 Arnold, Märklin, Lenz, Digitrax, Roco and Zimo are registered trade marks.