



4-fold turnout decoder

from the *Digital-Professional-Series* !

S-DEC-4-MM-F Part-No.: 910312

(With possible external power supply)

>> finished module <<

Compatible to Märklin-Motorola-Format:

(e.g. Märklin-Digital~ [Control Unit, Central Station 1 und 2], Intellibox, EasyControl, ECoS, KeyCom-MM, DiCoStation, EDiTS, EDiTS pro and others)

For digital control of:

- ⇒ up to 4 twin-coil magnet accessories (e.g. turnouts or signals).
- ⇒ up to 8 single-coil magnet accessories (e.g. uncoupling tracks).
- ⇒ up to 4 permanent power switch units [DSU] (e.g. illumination).

This product is not a toy! Not suitable for children under 14 years of age!
The kit contains small parts, which should be kept away from children under 3!
Improper use will imply danger of injuring due to sharp edges and tips! Please store this instruction carefully.



red point



Introduction/Safety instruction:

You have purchased the 4-fold turnout decoder **S-DEC-4** for your model railway as a kit or as finished module.
The **S-DEC-4** is a high quality product that is supplied within the assortment of Littfinski DatenTechnik (LDT).

We wish you having a good time using this product.

The turnout decoder **S-DEC-4** of the *Digital-Professional-Series* can be easily installed and used on your digital railway.

The **colored point** on the receiver device indicates to which digital system the decoder can be adapted.

In case the **receiver device** is marked **red** the decoder is suitable for **Märklin-Digital~** respectively for **Märklin-Motorola** layouts.

In case the **receiver device** is marked **yellow** the **S-DEC-4** will be suitable for the **DCC Data format**, used for instance at the systems of **Lenz-Digital Plus**, **Arnold-**, **Märklin-Digital=**, **Intellibox**, **TWIN-CENTER**, **Roco-Digital**, **EasyControl**, **ECoS**, **KeyCom-DC**, **Digitrax**, **DiCoStation** and **Zimo**.

The decoder **S-DEC-4** is **multi digital** and can be installed to the **Intellibox** without any problems.

The finished module comes with **24 month warranty**.

- Please read the following instructions carefully. Warranty will expire due to damages caused by disregarding the operating instructions. **LDT** will also be not liable for any consequential damages caused by improper use or installation.
- Also, note that electronic semiconductors are very sensitive to electrostatic discharges and can be destroyed by them. Therefore, discharge yourself before touching the modules on a grounded metal surface (e.g. heater, water pipe or protective earth connection) or work on a grounded electrostatic protection mat or with a wrist strap for electrostatic protection.
- We designed our devices for indoor use only.

Connecting the decoder to your digital model railway layout:

- **Attention:** Before starting the installation switch off the drive voltage by pushing the stop button from the command station or disconnect the main supply.

The decoder receives the **digital information** via the clamp **KL1**. Connect the clamp with a rail or even better connect the clamp directly to the command station or to a booster assuring supply of digital information free from any interference.

Pay attention to the mark at clamp **KL1**. The color markings **'Black/Schwarz'** and **'Red/Rot'** next to the clamp are used for **Arnold-Digital (old)** and **Märklin-Digital=**.

Other systems are using the letters **'J'** and **'K'**.

If you use the decoder for a **Märklin-Digital~** respectively **Märklin-Motorola** installation please attend to the colors marks **'red/rot'** and **'brown/braun'**.

The decoder receives the **voltage-supply** via the clamp **KL2**. The voltage shall be in the range of 12 to 18V~ (alternating voltage output of a model railway transformer) or 15 to 24Volt = (direct voltage output of an insulated power supply unit).

Now connect turnouts, signals, uncoupling tracks or the permanent power switch unit [DSU] to the 3-pole clamp marked 1 to 4.

The common conductor of a double coil (turnout or signal) has to be connected to the middle clamp of the relevant decoder output clamp. The two remaining cables mostly marked with red (turnout round) and green (turnout straight) shall be connected to the clamps marked **'G'** and **'R'** accordingly.

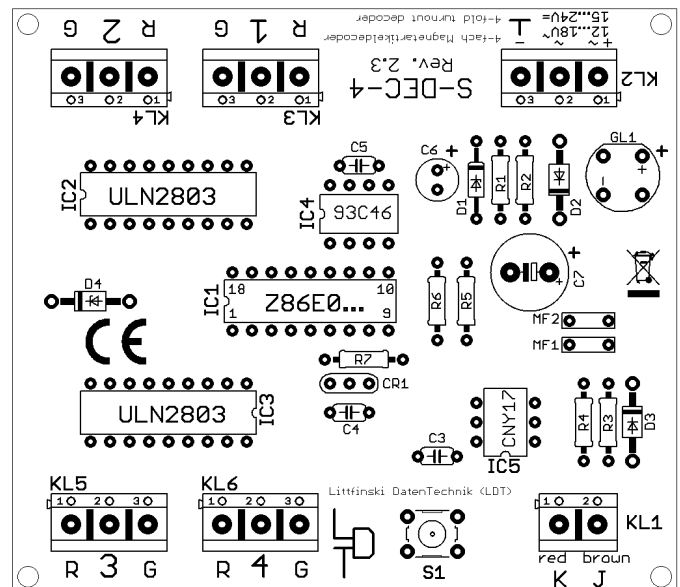

Programming the decoder address:

To program the decoder address a turnout has to be connected to the output 1 of the decoder.

- Switch on the power supply of your model rail way.
- Press the programming key S1. Do not touch the integrated circuits of the pc-board because any electrostatic discharge can destroy the IC's.
- The turnout connected to output 1 will move now automatically every 1.5 seconds. This indicates that the decoder is in the programming mode.

- Switch now one turnout of the **group of four** assigned to the decoder via the keyboard of the control unit or via a remote control. For programming the decoder address you can also release a turnout switch signal via a personal computer.

Remarks: The decoder addresses for magnet accessories are combined in **groups of four**. The address 1 to 4 build the first group. The address 5 to 8 build the second group etc. Each **S-DEC-4** decoder can be assigned to any of these groups. Which turnout of a group will be activated for the addressing does not matter.

- If the decoder has recognized the assignment correctly the connected turnout will move a little faster. Afterwards the movement slows down to the initial 1.5 seconds again. In case the decoder will not recognize the address it could be that the two digital information connections (clamp1) are wrong connected. For testing this, switch the power supply off, exchange the connection on KL1 and start addressing again.
- Leave the programming mode by pressing the programming key S1 again. The decoder address is now permanently stored but it can be changed at any time by repeating the programming as described above.
- If you press the first key of the programmed group of keys or you send a switch signal for this turnout from a PC the addressed turnout should move into the called direction either into round or into straight. In case the movement goes the wrong way please exchange the two turnout connection cables at the **G**reen (straight) and **R**ed (round) marked connection clamps of the decoder output 1.

Besides the typical application of **turnout control** the decoder can also be used for **uncoupling tracks and signals**.

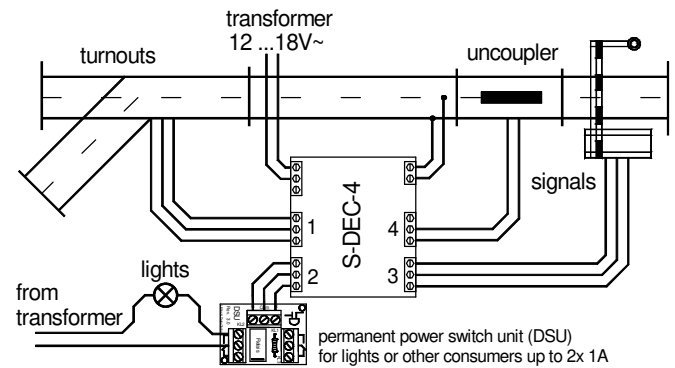

With our **permanent power switch unit [DSU]**, which is equipped with a bi-stable relay is it possible to switch lights or other consumers up to 2x **1A** digital on or off.

Further application and circuit examples can be found in the **Internet** on our **Web-Site** (www.ldt-infocenter.com) at the section **downloads**.

Under **LDT-01** you can purchase a low priced durable suitable **case** for the decoder **S-DEC-4**.

Please consult our Web-Site for further details.

Trouble shooting:

What to do if something is not working as described above? If you have purchased the decoder as a kit please carefully check all parts and soldered joints.

Here some possible functional errors and possible solutions:

- During **programming of the decoder addresses** the turnout moves within 1.5 seconds, but does not **confirm** the programming with **faster movement** by **pressing any key**.

- Change cable connections at KL1.**
 - Interfered digital information at KL1** respectively **lost of voltage** at the **tracks** or at the **installation!**
Connect the decoder directly with cables to the digital control unit or to the booster instead to the tracks. Increase the cable diameter for long distances.
 - Eventually the **clamps** have been **tightened to strong** and therefore the clamps got **loose at the soldering** to the pc board. **Check the soldering connection of the clamps** at the lower side of the pc-board and re-solder them if required.
 - For kits:** Is IC5 correct inserted into the socket? Has resistor R6 actually 220 kOhm or has this resistor been mixed-up with the 18kOhm resistor R5 respectively with the 1MOhm resistor R7?
- The **programming of the decoder address** functions as described, nevertheless the **turnouts** will not be activated.
 - Interfered digital information on KL1** respectively larger **lost of voltage** at the **tracks** or the **installation** result to unsafe data transfer! Connect the decoder directly to the command station or the booster. Increase the cable diameter of long distance connection cables.
 - For the kit:** Is IC4 correct inserted into the socket?

Please attend to the following:

- All 4 **decoder outputs** can switch a current of **1 Ampere** peak. Modern turnout drives need about 0.25 up to 0.5 Ampere. Older drives which are not free moving or which are dirty need more Ampere. The **S-DEC-4 Decoder** is **protected** against **overload** caused by **drives** which are not switching off at the end movement. The protector is an **automatic fuse** which will switch back into normal operation a few seconds after the load current is below maximum value.
- Turnouts with **integrated end-switch** can create considerable **electromagnetic interference**. Normally the decoder **S-DEC-4** will not be influenced by this interference. In case the decoder will be influenced please check the **turnout installation cables**. Those cables should not wrap or cross the decoder closely. Install the cables that way that they go straight away from the clamps of the decoder. If limited space requires a bad installation layout and the function of the decoder will be disturbed please disconnect the middle cable of each turnout connection and push about 5 to 10 ferrous pearls onto this cable before connecting to the clamp again.
- These ferrous pearls are available at electronic shops or at LDT with the order code 'FP'.
- Turnout illumination:** If you want to have a realistic switching of the turnout lights you can use the LDT **permanent power switch unit [DSU]** or our **switch decoder SA-DEC-4**.

Decoder application:

The below draft provides examples of the multipurpose application of the decoder **S-DEC-4**.

Made in Europe by
Littfinski DatenTechnik (LDT)
 Bühler electronic GmbH
 Ulmenstraße 43
 15370 Fredersdorf / Germany
 Phone: +49 (0) 33439 / 867-0
 Internet: www.ldt-infocenter.com

Subject to technical changes and errors. © 09/2022 by LDT
 Arnold, Digitrax, Lenz, Märklin, Motorola, Roco and Zimo are registered trade marks.